

High Efficiency PFM Step-up DC/DC Converter

FEATURES

- PFM control Asynchronous Booster
- Up to 90% Efficiency
- Quiescent Supply Current: 5 μ A
- Zero Shutdown current
- Output Voltage Accuracy: $\pm 1\%$
- Fixed Output Voltage
- Provides 20mA from single AAA cell
- Input Voltage Range: 0.8V to 5.5V
- Startup Voltage : 0.9V
- 3L SOT-23 and 6L SOT-26 Package

APPLICATIONS

- Wireless mice, keyboard
- Pagers
- Remote Controls
- Wireless Headsets
- Wireless Transmitters
- Personal Medical Devices
- Digital Still Cameras
- MP3/MP4 Players
- Single-Cell Battery-Powered Devices
- Low-Power Hand-Held Instruments

DESCRIPTION

The PS0021 compact, high-efficiency, step-up DC-DC converters are available in tiny, 3-pin thin SOT23 and 6-pin thin SOT26 packages. They feature an extremely low 5 μ A quiescent supply current to ensure the highest possible light-load efficiency. Optimized for operation from one to two alkaline or nickel-metal-hydrate (NiMH) cells, or a single Li+ cell, these devices are ideal for applications where extremely low quiescent current and ultra-small size are critical.

The PS0021 also feature proprietary noise-reduction circuitry, which suppresses electromagnetic interference (EMI) caused by the inductor in many step-up applications. The family offers different combinations of fixed outputs, shutdown, and EMI reduction (see Selector Guide).

Its unique design is optimized for high efficiency at light load condition.

TYPICAL APPLICATION CIRCUIT

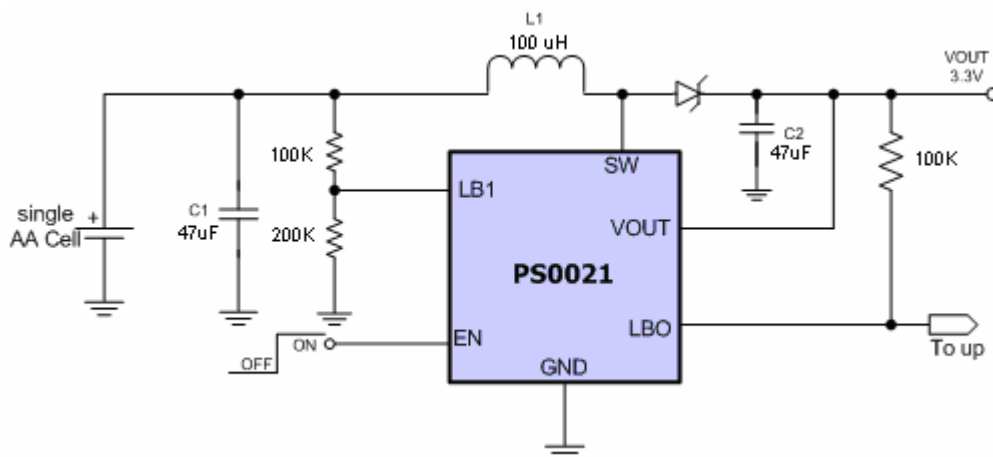

PIN CONFIGURATION

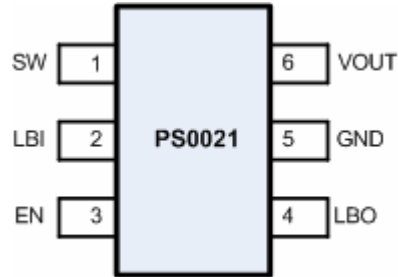

PIN DESIGNATOR

Name	Pin	Type	Function
SW	1	Switch	Connect inductor between SW and Battery.
LBI	2	Low-Battery Detector Input.	Connect a resistive divider from Battery to LBI to ground.
EN	3	Enable	EN=High: normal operation. (Supports both TTL and CMOS Logic).
LBO	4	Low Battery Detector Output	Open-Drain Output. Low-Battery Detector Output is LOW when VLBI is less than 0.6 V.
GND	5	Ground	Power Ground
VOUT	6	IC Power Supply	VOUT supplies power to Step-up converter.

Note 1: Limits are 100% production tested at TA = +25°C. Limits over the operating temperature range are guaranteed by design.

Note 2: Guaranteed with the addition of a Schottky MBR0520L external diode between LX and OUT when using the PS0021 with only one cell, and assumes a 0.3V voltage drop across the Schottky diode (see Figure 3).

Note 3: Supply current is measured with an ammeter between the output and OUT pin. This current correlates directly with actual battery supply current, but is reduced in value according to the step-up ratio and efficiency.

Note 4: VOUT forced to the following conditions to inhibit switching: $V_{OUT} = 1.05 \times V_{OUT} (NOM)$
 $V_{OUT} = 3.465V$

BLOCK DIAGRAM

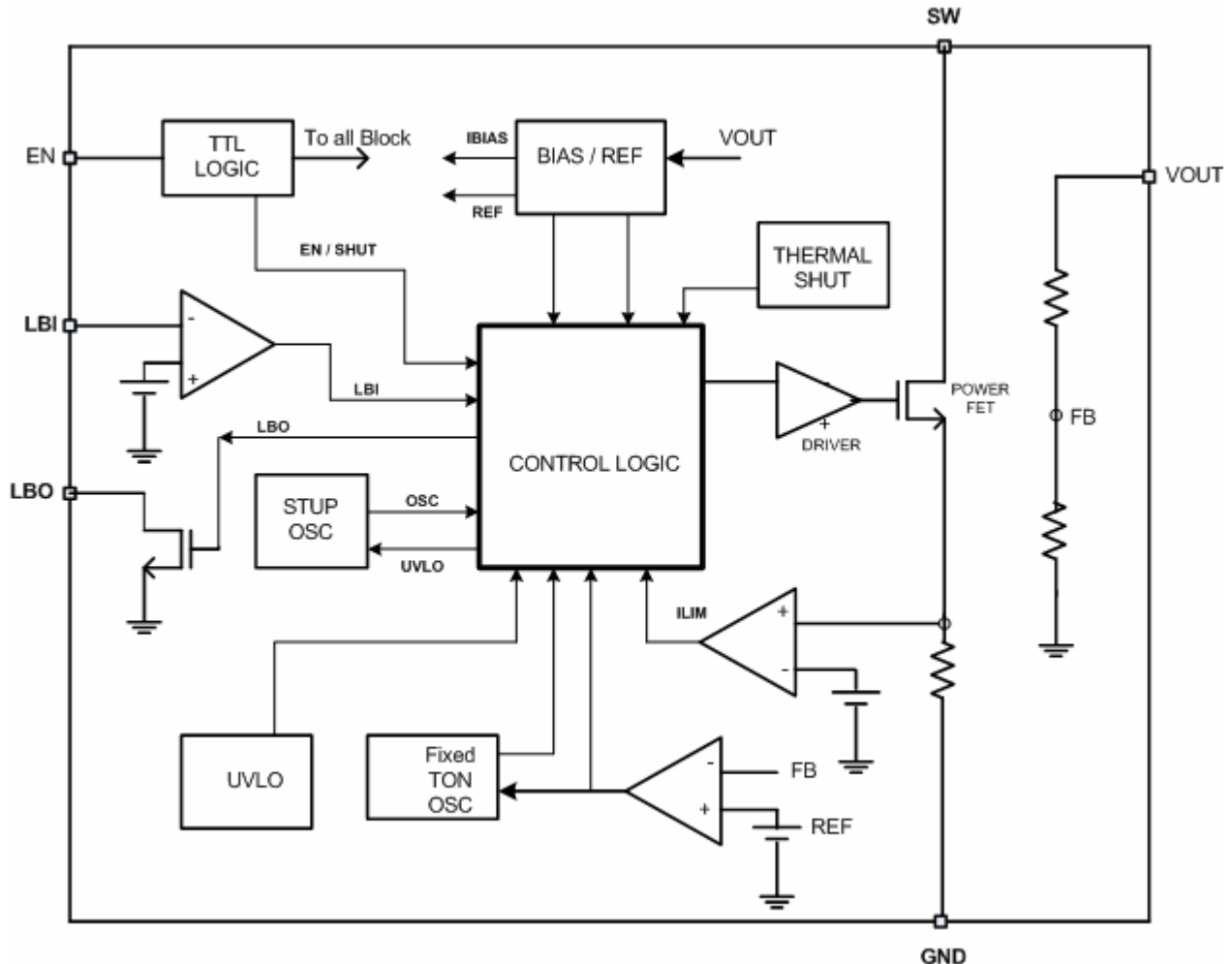

ABSOLUTE MAXIMUM RATINGS

OUT, SHDN, BATT, SW to GND	-0.3V to +6V
FB to GND	-0.3V to (VOUT + 0.3V)
OUT, SW Current	1A
Continuous Power Dissipation (TA = +70°C)	
6-Pin Thin SOT26 (derate 7.1mW/°C above +70°C)	571mW
Operating Temperature Range	-40°C to +85°C
Junction Temperature	+150°C
Storage Temperature Range	-65°C to +150°C
Lead Temperature (soldering, 10s)	+300°C

ELECTRICAL CHARACTERISTICS

($V_{BATT} = 1.2V$, $V_{OUT} = 3.3V$, $V_{OUT} = V_{OUT(NOM)}$, SHDN = OUT, $R_L = \infty$, $T_A = 0^\circ C$ to $+85^\circ C$, unless otherwise noted. Typical values are at $T_A = +25^\circ C$.)

Parameter	Symbol	Conditions	Min	Typ	Max	Unit
Operating Input Voltage	V_{IN}	(Note 2)			5.5	V
Output Voltage variation	V_{OUT}		3.2	3.3	3.4	V
Minimum Startup Input Voltage		$R_L = 30k\Omega$		0.9		V
Hold on Voltage		1 mA load		0.7		V
Switch leakage				5		nA
N-Channel On-Resistance	$R_{DS(ON)}$	Measured from SW pin voltage and inductor current during SW on time		1.4		Ω
Maximum oscillating freq	F_{OSC}	V_{OUT} forced = $V_{OUT(NOM)} * 0.95$	80	100	120	KHz
Duty ratio	D_{MAX}	V_{OUT} forced = $V_{OUT(NOM)} * 0.95$	65	75	85	%
Efficiency	Eff			85		%
Quiescent Current into OUT (no switching)		$V_{IN} = V_{OUT} + 0.5V$ measurement of the IC input current(V_{OUT} pin) (Notes 3, 4)		5		μA
Quiescent Current into OUT		V_{OUT} forced = $V_{OUT(NOM)} * 0.95$		25		μA
Shutdown Current into OUT		(Notes 4) $E_n = 0V$		1		μA
SHDN Voltage Threshold	V_{IL}		1.2			mV
	V_{IH}				0.4	
SHDN Input Bias current		$V_{SHDN} = 5.5V$		1.1		nA

Low Battery Detector					
LBI voltage threshold	V_{OUT} forced = $V_{OUT(NOM)} * 1.05$	665	670	675	mV
LBI input hysteresis	V_{OUT} forced = $V_{OUT(NOM)} * 1.05$	15	18	22	mV
LBI input current	V_{OUT} forced = $V_{OUT(NOM)} * 1.05$		0.02		nA
LBO output low voltage	Force 20mA into LBO	0.45	0.50	0.6	V
LBO output leakage current	LBO = 6.0V		0.1		μA

TYPICAL OPERATING CHARACTERISTICS

(All specifications are at $T_A = +25^\circ\text{C}$, $V_{IN} = 1.5\text{V}$, circuit of typical application circuit, unless otherwise specified.)

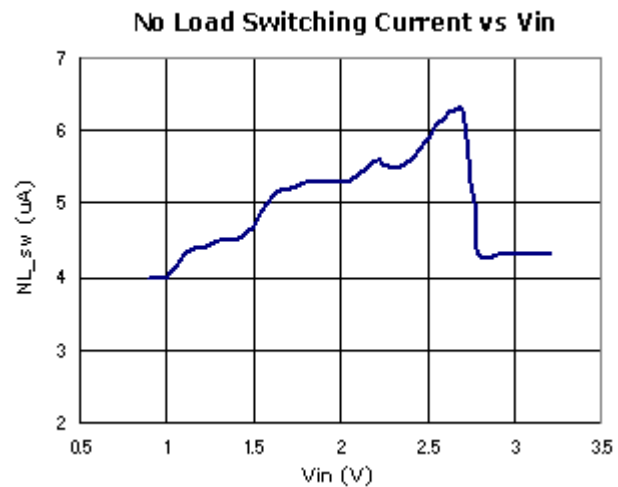
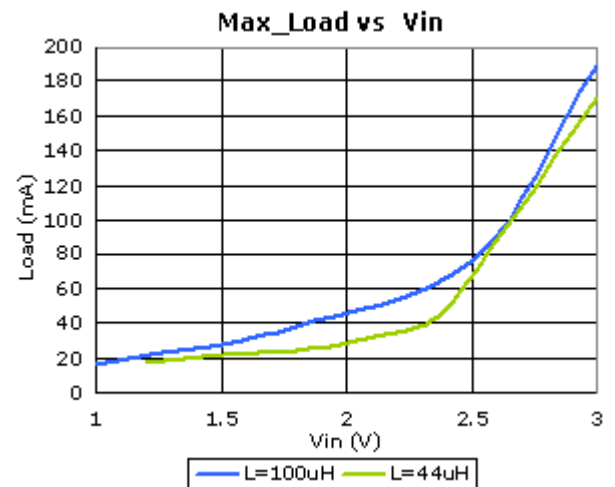
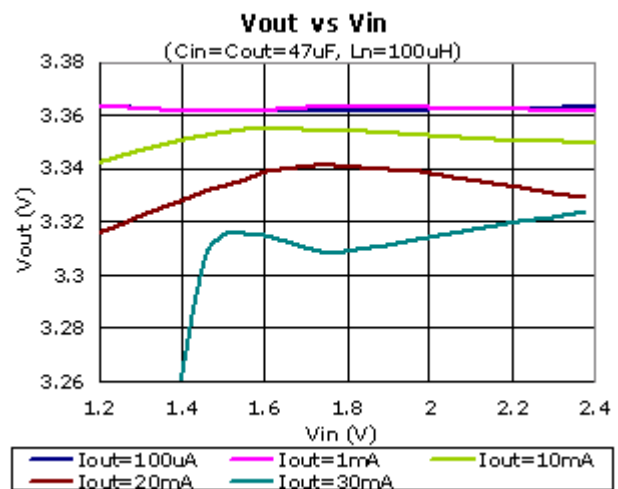
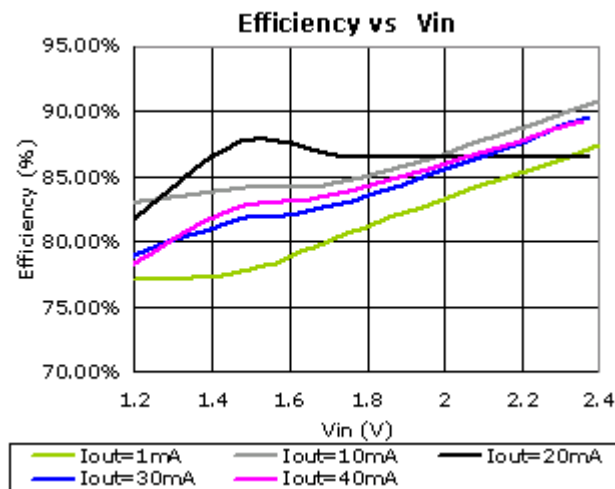
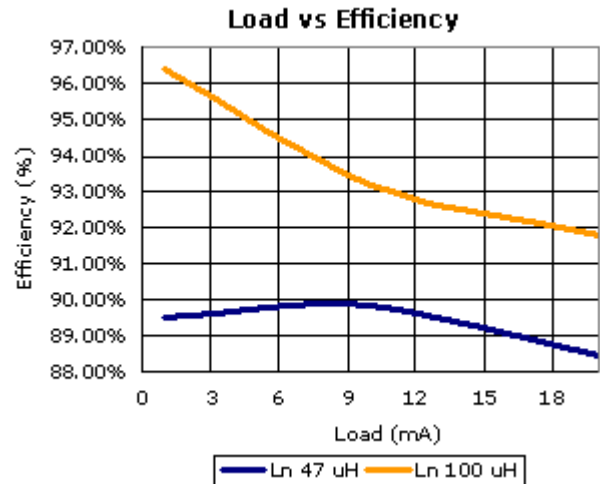
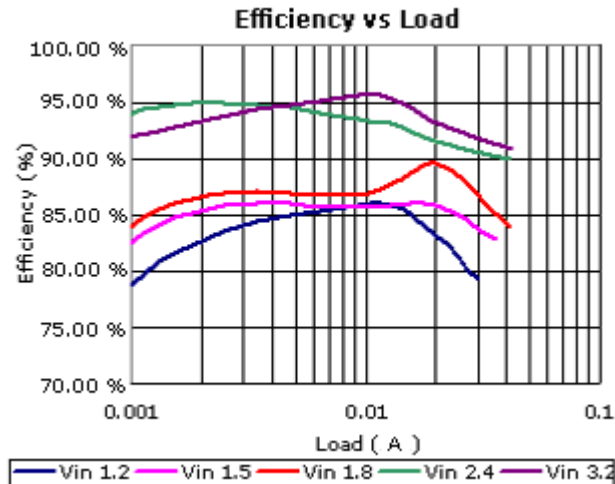

TYPICAL OPERATING CHARACTERISTICS (continued)

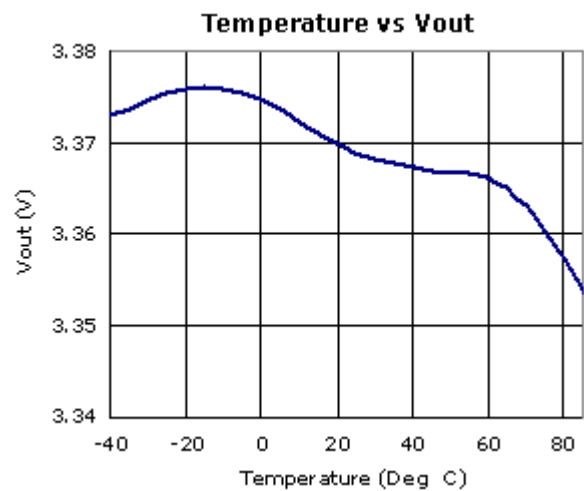
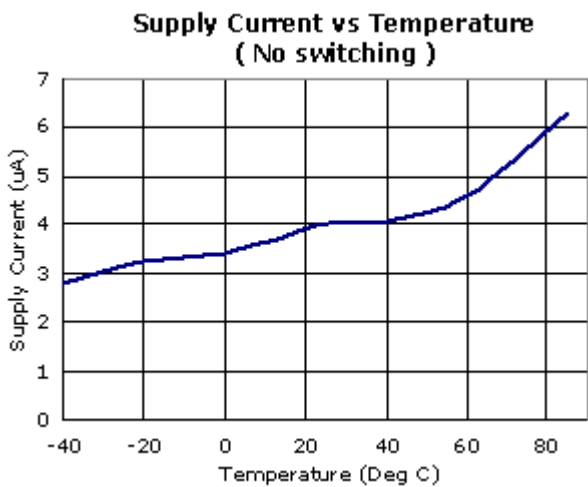
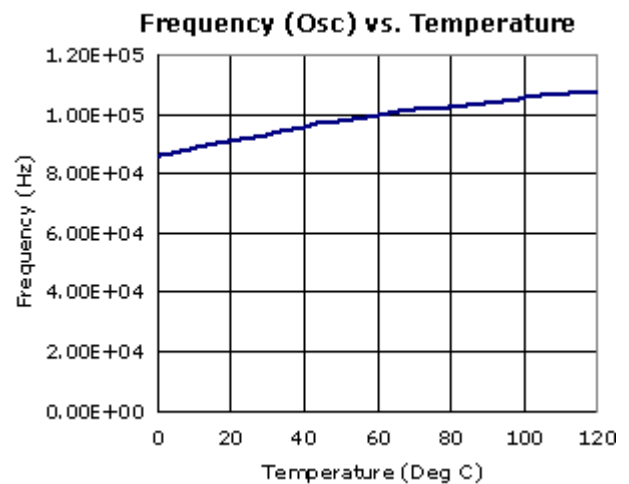
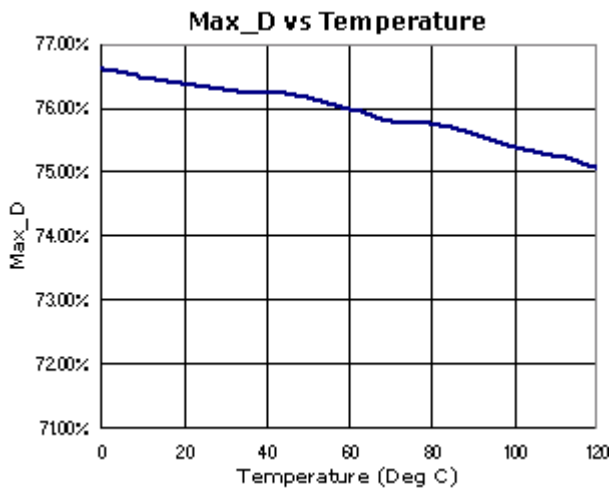
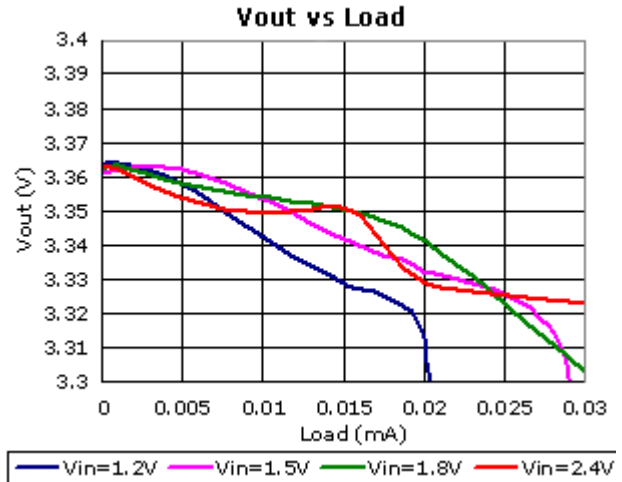
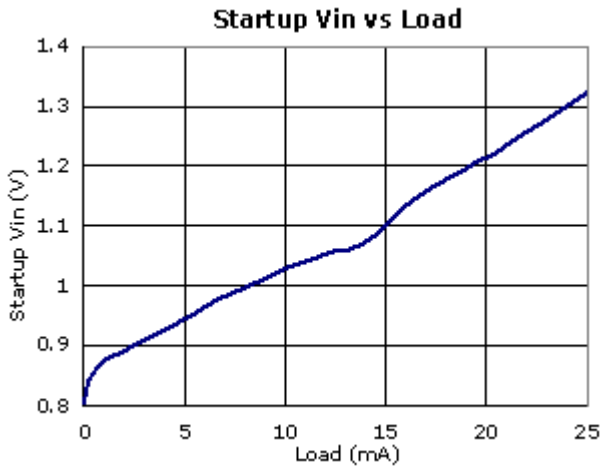

TYPICAL OPERATING CHARACTERISTICS (continued)

Supply Current vs Temperature (Switching)

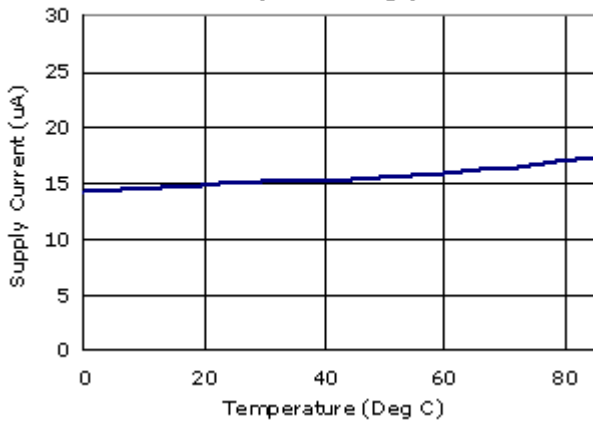

Load Transient Response

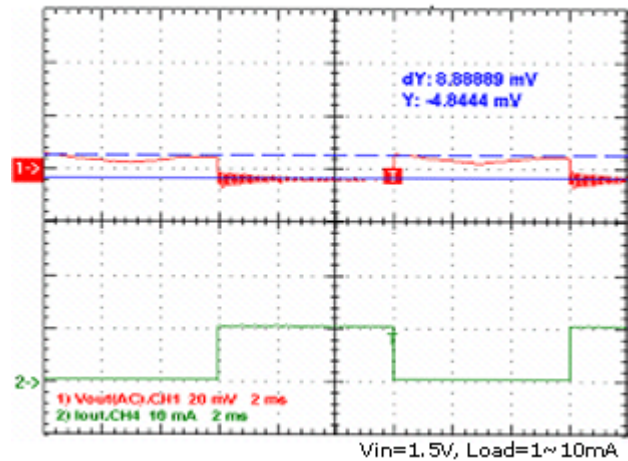

Load Transient Response

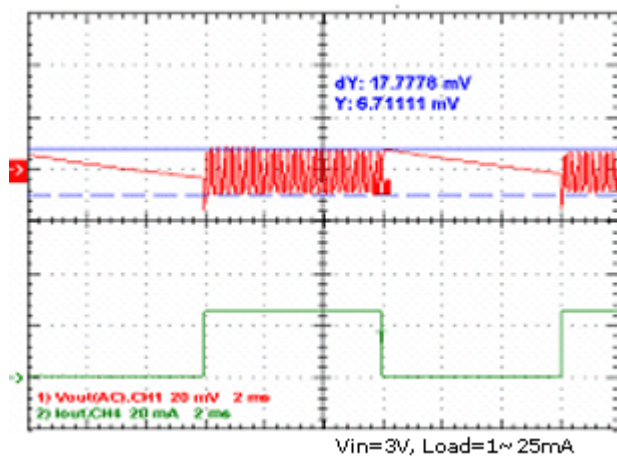

Line Transient Response

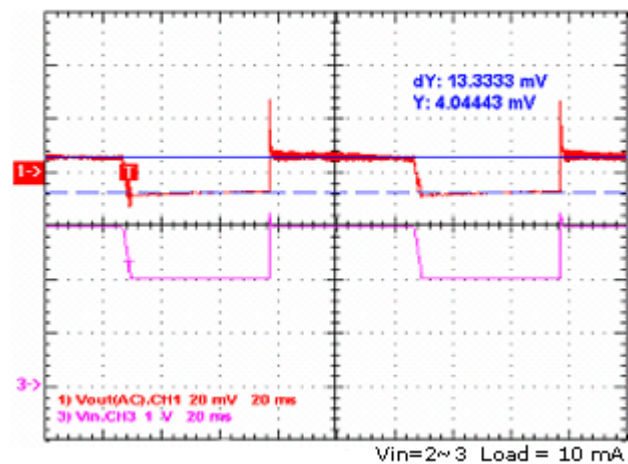

Ripple Voltage vs Load

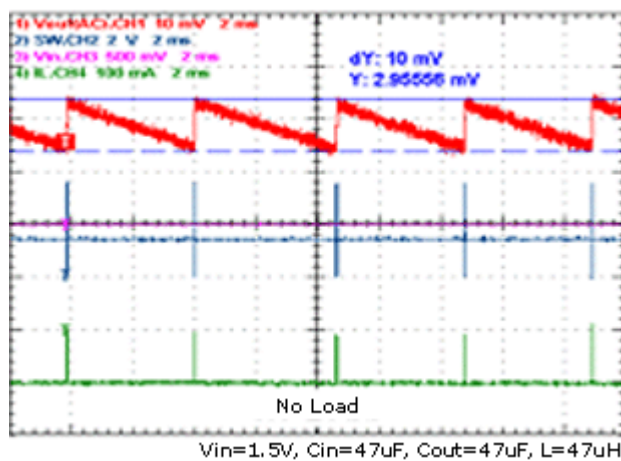

Ripple voltage in continuous mode

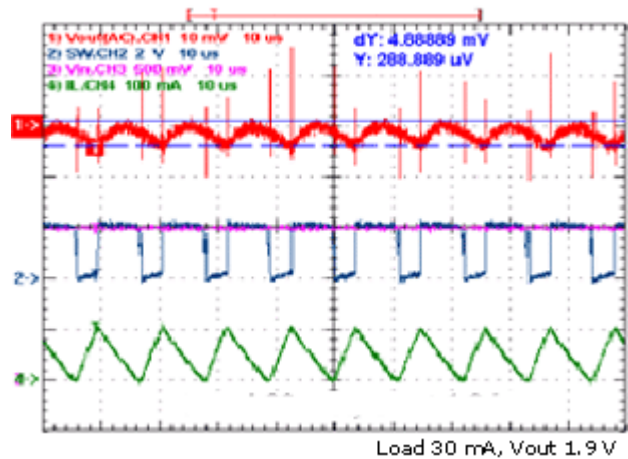

TYPICAL OPERATING CHARACTERISTICS (continued)

Start-up Time after Enable

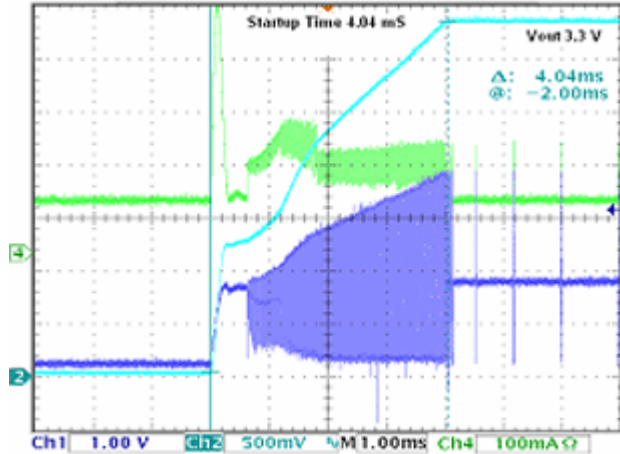

Current Limit vs Vout

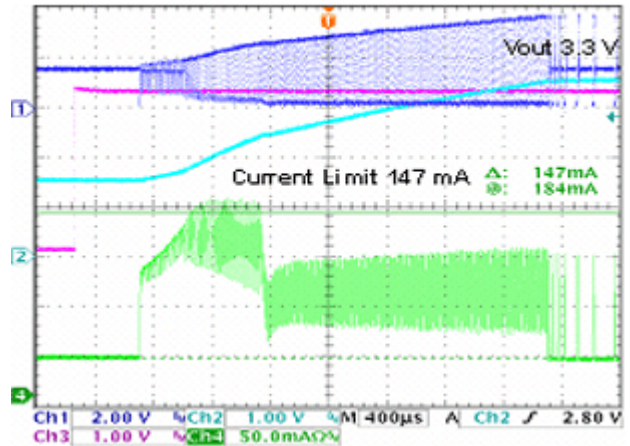

Ripple Voltage vs Load

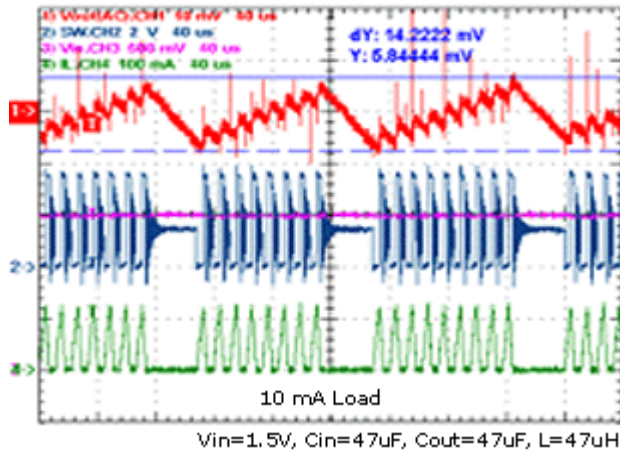

Ripple Voltage in discontinuous Mode

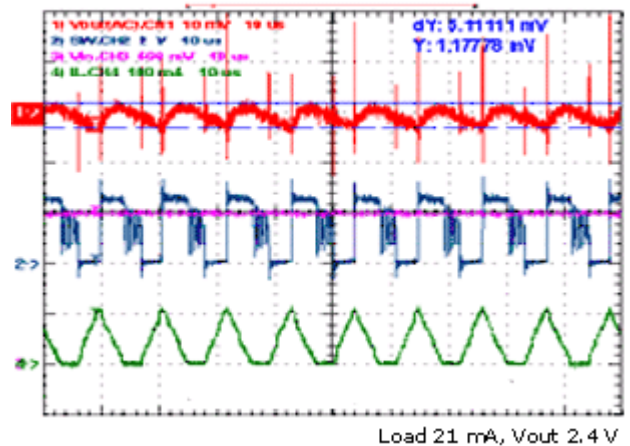

OPERATION

The PS0021 is a compact, high-efficiency, synchronous boost converter in a SOT-26 package designed for space-restricted applications. The part is available with adjustable output voltages ranging from 2.5V to 5.0V. It is able to start up with input voltages as low as 0.8V and operate with input voltages down to 0.5V. With its internal synchronous rectifier and low on-resistance of the internal NMOS switch, the device maintains high efficiency over a wide range of load current. As shown in the Block Diagram, the PS0021 consists of accurate band gap core, error amplifier, start-up oscillator and control logic unit along with PMOS and NMOS switches. With current mode PWM control, the PS0021 has ultra-fast line and improved load regulation. Moreover, the PS0021 provides real shutdown circuitry which disconnects the output from the input during shutdown and results in the discharge of the output to ground.

Start-Up Mode

The PS0021 starts up typically at 0.8V. When it is turned on, the device gets its start up bias from V_{IN} . A start-up oscillator, which runs typically at 650 KHz, takes the output voltage high enough so that V_{OUT} exceeds V_{IN} . Once V_{OUT} exceeds V_{IN} , the internal bias switches from V_{IN} to V_{OUT} by an internal bias-select circuit. Thus, once started (i.e. V_{OUT} exceeds V_{IN}), the internal circuit bias is completely independent of V_{IN} . The start-up oscillator runs at 66% duty cycle at around 650KHz. Once V_{OUT} exceeds V_{IN} (typically 1.9V), the start-up oscillator is disabled and the normal fixed T_{ON} PWM operation takes over.

Internal PMOS and NMOS Switches

The PS0021 features a 0.45Ω NMOS switch and a 0.6Ω PMOS switch. In normal operation, these switches are alternatively turned on and thus initiate the charging of the inductor from V_{IN} and then discharging of it to the output capacitor and the load. However, between the event of one switch turning off and the other turning on, a dead time is provided to avoid a huge in-rush current from the output to ground via switches. During the dead time, both switches remain off and the inductor discharges via the body diode of the PMOS switch to the output.

Thermal Overload Protection

Thermal overload protection limits the total power dissipation in the PS0021. When the junction temperature exceeds $T_J = +145^\circ\text{C}$, the thermal sensor signals the shutdown logic and turns off most of the internal circuitry. The thermal sensor turns the internal circuitry on again after the IC's junction temperature drops by 15°C .

Thermal overload protection is designed to protect the PS0021 in the event of a fault condition. For continuous operation, do not exceed the absolute maximum junction temperature rating of $T_J = +125^\circ\text{C}$.

Current Limit Protection

The PS0021 includes a current limiter that monitors the peak inductor current through the NMOS switch and turns the NMOS switch off when the inductor peak current exceeds 150mA.

Light Load Operation

The PS0021 provides improved light load efficiency. The internal zero current comparator monitors the inductor current to the load and shuts off the PMOS switch once this current reduces to some low value (typically 50mA). This prevents the inductor current from reversing its polarity, avoiding back-charging and thus improving the efficiency at light loads. At that time, both the NMOS and PMOS switches remain off. However, normal operation starts again when the output voltage falls below the regulation point. The IC automatically skips pulses at light load, thus providing better efficiency.

Under Voltage Lockout

When the supply becomes too low (typically below 1.8V), the PS0021 produces an internal UVLO (Under Voltage Lockout) signal that disables the normal PWM operation and enables the start-up oscillator to run at a fixed frequency. At this stage, very few circuits are operational. When the oscillator raises the supply to above 1.9V, the UVLO signal is disabled and the normal PWM mode takes over the operation of the start-up oscillator. This mechanism protects the chip from producing false logic due to low input supply.

Enable Input

The PS0021 features an active-high CMOS input enable pin (SHUTB) that allows on/off control of the regulator. When SHUTB=Low, shutdown of the chip occurs and at that time almost no quiescent current ($<1\mu\text{A}$) flows. The output capacitor can be completely discharged through the load or the feedback resistors for real output shutdown. A discharge switch is internally connected between VIN and SW. The Enable (SHUTB) input is TTL/CMOS compatible. Connect SHUTB to VIN for normal operation.

Track Mode

In track mode Vout follows Vin. Difference between Vout and Vin is determined by the load current and the schottky forward voltage drop at that current.

PACKAGE INFORMATION

SOT-26 Outline Dimensions (Unit: mm)

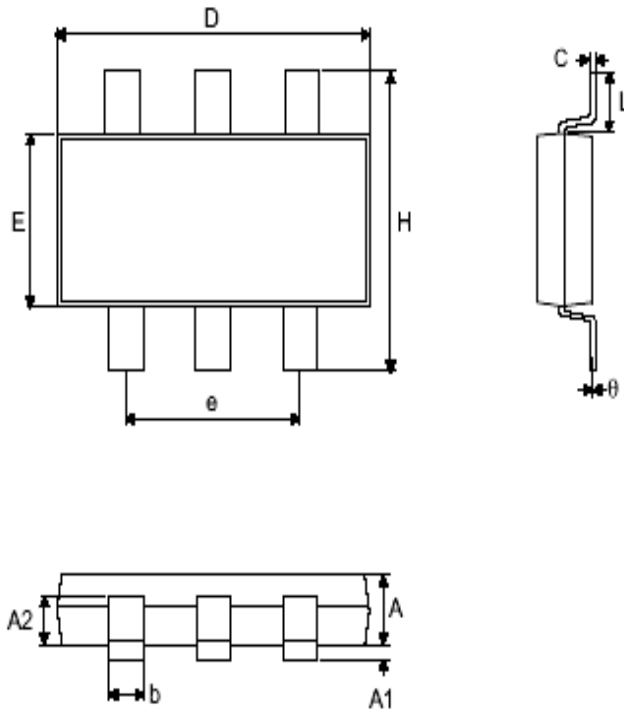

Pin	Parameter										
	A	A1	A2	b	C	D	E	e	H	L	θ
6	1~1.3	0.1 max.	0.7~0.9	0.35~0.5	0.1~0.25	2.7~3.1	1.4~1.8	1.9 typ.	2.6~3	0.37 min.	$1^{\circ}\sim 9^{\circ}$

DISCLAIMERS

LIFE SUPPORT

Power IC's products are NOT designed to be used as components in devices intended to support or sustain human life. The use of Power IC's products in components intended for surgical implants into the body or other applications, in which failure of Power IC's products could create a situation where personal death or injury may occur, is NOT authorized without the express written approval of Power IC's Chief Executive Officer. Power IC will NOT be held liable for any damages or claims resulting from the use of its products in medical applications.

MILITARY

Power IC's products are NOT designed for use in military applications. The use of Power IC's products in military applications is NOT authorized without the express written approval of Power IC's Chief Executive Officer. Power IC will NOT be held liable for any damages or claims resulting from the use of its products in military applications.

RIGHT TO MAKE CHANGES

Power IC reserves the right to change this document and/or this product without notice. Customers are advised to consult their Power IC sales representative before ordering.