

## FEATURES

- 300mA+300mA dual channel high accuracy LDO
- Ultra low output noise:  $140\mu\text{V}_{\text{RMS}}$
- Low ground current:  $200\mu\text{A}$
- Very low dropout:  $150\text{mV}$  @300mA
- Zero shutdown supply current
- TTL-logic-controlled independent enable input
- Thermal and current limit protections
- Ultra low droop load transient response
- Ultra fast line transient response
- Tiny 10pin 3mm x 3mm MLF (10L-TDLMF) package
- Fixed options 1.5V, 1.8V, 2.5V, 2.8V, 3.0V and 3.3V

## APPLICATIONS

- Dual supply handheld products
- Cellular and cordless phones
- Wireless LAN cards
- Digital camera
- MP3 / MP4 / CD player
- Pen drives
- USB Hubs and USB 2.0
- Mini PCI & PCI express cards

## TYPICAL APPLICATION

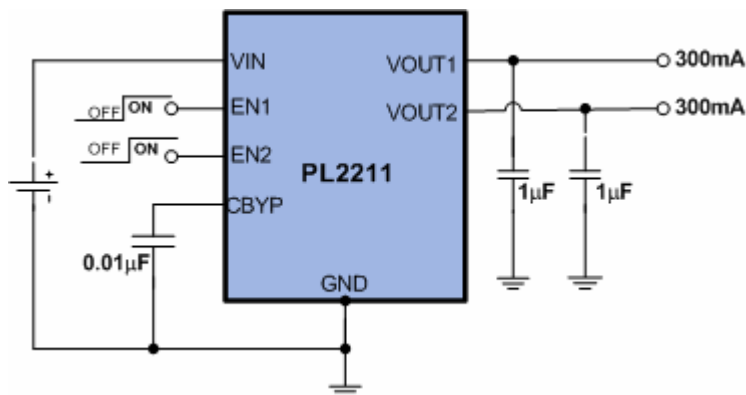

## DESCRIPTION

The PL2211 is a dual CMOS low dropout linear regulator with ultra-low-noise output, very low dropout voltage and very low ground current.

The PL2211 operates from a 2.5V to 5.5V input voltage range and delivers up to 300mA, with low dropout of  $150\text{mV}$  at 300mA. The other features of PL2211 include short-circuit protection and thermal-shutdown protection.

Its dual channel and low noise feature is ideal for microcontroller and DSP based handheld applications.

Other key application areas for PL2211 also include palmtop computers, PCMCIA cards and WLAN cards.

The PL2211 has a special feature that if both EN pin is enabled simultaneously the output of LDO2 delays 20us from output of LDO1 which helps to minimize inrush startup current.

The PL2211 is available in tiny 10pin 3mm x 3mm MLF (10L-TDLMF) package with fixed output voltage versions.

## PIN CONFIGURATION

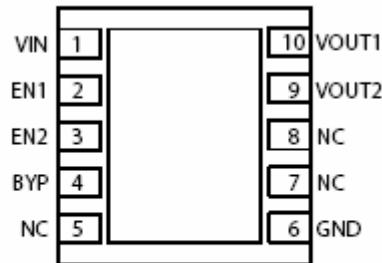

10-Pin 3mm × 3mm MLF™ (ML)  
(Top View)

## ORDERING INFORMATION

Part Number	Output Voltage	Marking	Package
PL2211 – 15VZ	1.5	DBAMW	10L-TDLMF
PL2211 – 15UZ	1.5	DBBMW	10L-TDLMF
PL2211 – 18VZ	1.8	DBCMW	10L-TDLMF
PL2211 – 18UZ	1.8	DBDMW	10L-TDLMF
PL2211 – 25VZ	2.5	DBEMW	10L-TDLMF
PL2211 – 25UZ	2.5	DBFMW	10L-TDLMF
PL2211 – 27VZ	2.7	DBGMW	10L-TDLMF
PL2211 – 27UZ	2.7	DBHMW	10L-TDLMF
PL2211 – 28VZ	2.8	DBIMW	10L-TDLMF
PL2211 – 28UZ	2.8	DBJMW	10L-TDLMF
PL2211 – 30VZ	3.0	DBKMW	10L-TDLMF
PL2211 – 30UZ	3.0	DBLMW	10L-TDLMF
PL2211 – 33VZ	3.3	DBMMW	10L-TDLMF
PL2211 – 33UZ	3.3	DBNMW	10L-TDLMF

Note 1: Contact the factory for other output voltages that are not in the above table

## PIN DESCRIPTIONS

Name	Pin No.	Type	Function
IN	1	Supply	Supply voltage. 2.5V ~ 5.5V.
EN1	2	Logic input 1	Enable/Shutdown. CMOS compatible input. Logic 'H' : enable, logic 'L' : shutdown.
EN2	3	Logic input 2	Enable/Shutdown. CMOS compatible input. Logic 'H' : enable, logic 'L' : shutdown.
BYP	4	Bypass	Reference voltage bypass pin. Connect $0.01\mu\text{F} \leq C_{\text{BYP}} \leq 0.1\mu\text{F}$ to GND to reduce output noise. May be left open.
GND	6	Ground	Ground pin
OUT2	9	Analog output2	Regulator 2 Output.
OUT1	10	Analog output1	Regulator 1 Output.

## BLOCK DIAGRAM

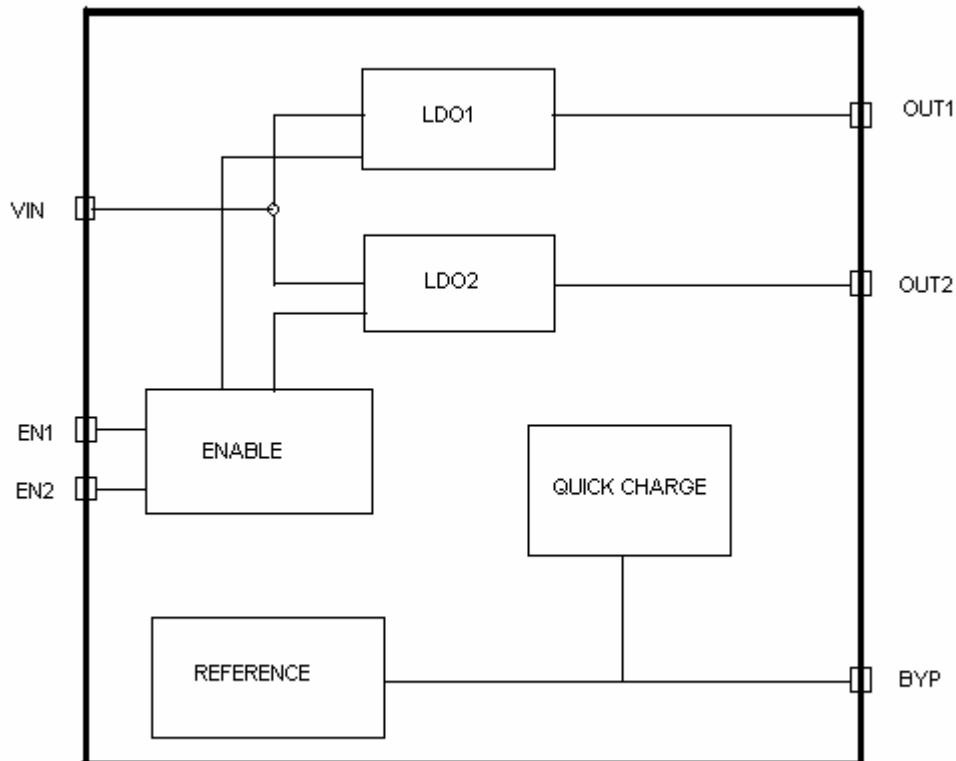

## ABSOLUTE MAXIMUM RATINGS

Symbol	Parameter	Value	Unit
$V_{IN}$	DC Supply Voltage at Pin 1	-0.3 to +6.0	V
$V_{EN}$	Enable Input Voltage at Pin 2 and Pin 3	-0.3 to +6.0	V
$P_D$	Continuous Power Dissipation	Internally limited	W
$T_{STG}$	Storage Temperature Range	-65 to +150	°C
$R_{\theta JA}$	Thermal Resistance, Junction-To-Air	235	°C/W
$T_{J,MAX}$	Operating Junction Temperature	-40 to +125	°C
$T_L$	Lead Temperature (Soldering, 5sec)	260	°C
ESD	ESD Capability, HBM model	2	kV

## RECOMMENDED OPERATING CONDITIONS

Symbol	Parameter	Value	Unit
$V_{IN}$	DC Supply Voltage at Pin 1	+2.5 to 5.5	V
$V_{EN}$	Enable Input Voltage at Pin 2 and Pin 3	0 to $V_{IN}$	V
$T_A$	Operating Ambient Temperature	-40 to +85	°C

## ELECTRICAL CHARACTERISTICS

( $V_{IN}=V_{OUT(NOMINAL)}+1V$  or 2.5V (whichever is greater),  $V_{EN}=V_{IN}$ ,  $C_{IN}=C_{OUT}=1\mu F$ ,  $I_O=1mA$ ,  $T_A=25^\circ C$ , unless otherwise noted.)

Symbol	Parameter	Test Conditions	Min.	Typ.	Max.	Unit
$V_{IN}$	Supply Voltage		2.5		5.5	V
$\Delta V_{OUT}$	Output Voltage Accuracy	$I_O = 1mA$ ( both regulator )	-1.0		1.0	%
$\Delta V_{LOAD}$	Load Regulation	$I_O=1mA$ to 300mA ( both regulator )			0.5	%
$\Delta V_{LINE}$	Line Regulation $dV_{OUT}/(dV_{IN}*V_{OUT(NOMINAL)})*100\%$	$V_{IN}=V_{OUT(NOMINAL)}+0.1V$ (or 2.5V, whichever is greater) to 5.5V, $I_O=1mA$ ( both regulator )			0.05	%/V
VDP	Dropout Voltage (Note 1)	$I_{LOAD} = 300mA$ ( both regulator )		150	220	mV
		$I_{LOAD} = 100mA$ ( both regulator )		80	100	mV
$I_O$	Maximum Output Current	Continuous	300			$mA_{RMS}$
ILIM	Current Limit/Output Current	$V_{IN}-V_{OUT} = 1.3V$ ( regulator 1 )	350	600		mA
		$V_{IN}-V_{OUT} = 1.3V$ ( regulator 2 )	350	600		
IQ	Standby Current	$V_{EN} = 0V$		0.02	1	$\mu A$
IG	Ground pin current	$I_{LOAD1} = I_{LOAD2} = 1mA$ ( both regulator active)		200	300	$\mu A$
PSRR	Ripple Rejection, $I_{OUT} = 10mA$ ,	$f = 100Hz$ , $C_{out}= 1\mu F$ , $C_{byp}=10nF$		75		dB
PSRR		$f = 10KHz$ , $C_{out}= 1\mu F$ , $C_{byp} = 10nF$		70		dB
	Output voltage noise	$C_{OUT} = 1\mu F$ , $C_{BYP} = 10nF$ , $F = 10Hz$ to 100K Hz ( $V_{p-p}/2/\sqrt{2}$ )		140		$\mu V_{RMS}$
	Thermal Shutdown Temperature			165		°C
	Thermal Shutdown Hysteresis			20		°C
$V_{IH}$	Logic Input High Voltage (EN)	( both regulator )	1.2			V
$V_{IL}$	Logic Input Low Voltage (EN\)	( both regulator )			0.4	V
IEN	Logic Input Current (SHDN\)	( both regulator )	-1		1	$\mu A$

Note 1: The Dropout Voltage is defined as  $V_{IN} - V_{OUT}$ , when  $V_{OUT}$  is 2% below the value of  $V_{OUT}$  measured for  $V_{IN}=V_{OUT(nominal)}+1V$ .

## OPERATION DESCRIPTION

The PL2211 are ultra-low-noise, low-dropout, low-quiescent current linear regulators designed for space-restricted applications. These devices can supply loads up to 300mA. As shown in the Block Diagram, the PL2211 consists of a highly accurate band gap core, noise bypass circuit, error amplifier, P-channel pass transistor and an internal feedback voltage divider. The 1.0V band gap reference is connected to the error amplifier's inverting input. The error amplifier compares this reference with the feedback voltage and amplifies the difference. If the feedback voltage is lower than the reference voltage, the pass transistor gate is pulled low. This allows more current to pass to the output and increases the output voltage. If the feedback voltage is too high, the pass transistor gate is pulled high, allowing less current to pass to the output. The output voltage is feedback through an internal resistor voltage divider connected to the OUT pin. An external bypass capacitor connected to BYP reduces noise at the output. Additional blocks include a current limiter, over temperature protection, and shutdown logic.

### Internal P-Channel Pass Transistor

The PL2211 feature a  $1\Omega$  (typ) P-channel MOSFET pass transistor. This provides several advantages over similar designs using a PNP pass transistor, including longer battery life. The P-channel MOSFET requires no base drive, which considerably reduces quiescent current. PNP-based regulators waste considerable current in dropout when the pass transistor saturates. They also use high base-drive current under heavy loads. The PL2211 does not suffer from these problems and consume only 200 $\mu$ A of quiescent current in light load.

### Current Limit

The PL2211 includes a current limiter. It monitors the output current and controls the pass transistor's gate voltage to limit the output current under 600mA (typ). The output can be shorted to ground for an indefinite amount of time without damaging the part.

### Enable Input

The PL2211 features an active-high Enable input (EN) pin that allows on/off control of the regulator. The PL2211 bias current reduces to less than microampere of leakage current when it is shutdown. The Enable input is TTL/CMOS compatible threshold for simple logic interfacing. When EN is 'H,' the output voltage startup rising time is 35 $\mu$ s typically at 300mA output current. Connect EN pin to IN pin for normal operation

### Under Voltage Lockout

When the input supply goes too low (below 2.0V) the PL2211 produces an internal UVLO (under voltage lockout) signal that generates a fault signal and shuts down the chip. This mechanism protects the chip from producing false logic due to low input supply.

### Quick Charging Mode

The PL2211 has a quick charge block to get the reference up very quickly by charging the BYP capacitor with very high current when the chip comes out of shut down. This quick charge block stops charging the BYP capacitor when the reference reaches 95% of its nominal value and then the chip switches out of quick charging mode to normal operating mode.

### Over Temperature Protection

Over temperature protection limits total power dissipation in the PL2211. When the junction temperature exceeds  $T_j = +165^\circ\text{C}$ , the thermal sensor signals the shutdown logic and turns off the pass transistor. The thermal sensor turns the pass transistor on again after the IC's junction temperature drops by  $20^\circ\text{C}$ , resulting in a pulsed output during continuous thermal-overload conditions.

Thermal-Overload protection is design to protect the PL2211 in the event of a fault condition. For continual operation, do not exceed the absolute maximum junction temperature rating of  $T_j = +150^\circ\text{C}$ .

## Operating Region and Power Dissipation

The PL2211 maximum power dissipation depends on 1) the thermal resistance of the case and circuit board, 2) the temperature difference between the die junction and ambient, and 3) the rate of airflow. The power dissipation across the device is:

$$P = I_{out} (V_{in} - V_{out})$$

The maximum power dissipation is:

$$P_{max} = (T_j - T_a) / (\theta_{jc} + \theta_{ca})$$

Where  $(T_j - T_a)$  is the temperature difference between the PL2211 die junction and the ambient air;  $\theta_{jc}$  is the thermal resistance of the package; and  $\theta_{ca}$  is the thermal resistance through the PC board, copper traces, and other materials to the surrounding air.

The GND pin of the PL2211 performs the dual function of providing an electrical connection to ground and channeling heat away. Connect the GND pin to ground using a large pad or ground plane.

## Noise Reduction

For the PL2211, an external 0.01 $\mu$ F bypass capacitor between BYP and GND with innovative noise bypass scheme reduces output noises dramatically, exhibiting 100 $\mu$ Vrms of output voltage noise with  $C_{byp} = 0.01\mu\text{F}$  and  $C_{out} = 1\mu\text{F}$ .

## APPLICATION INFORMATION

### Capacitor Selection and Regulator Stability

Use a 1 $\mu$ F capacitor on the PL2211 input and a 1 $\mu$ F capacitor on the output. Large input capacitor values and lower ESRs provide better noise rejection and line-transient response.

Reduce output noise and improve load-transient response, stability, and power-supply rejection by using large output capacitors. Note that some ceramic dielectrics exhibit large capacitance and ESR variation with temperature. With dielectrics such as Z5U and Y5V, it may be necessary to use a 1 $\mu$ F or larger output capacitor to ensure stability at temperatures below -10°C. With X7R or X5R

dielectrics, 1 $\mu$ F is sufficient at all operating temperatures. A graph of the region of stable Cout ESR vs. load current is shown in the Typical Characteristics.

Use a 0.01 $\mu$ F bypass capacitor at BYP for low-output voltage noise. The leakage current going into the BYP pin should be less than 10nA.

## Noise, PSRR, and Transient Response

The PL2211 are designed to deliver ultra-low noise and high PSRR, as well as low dropout and low quiescent currents in battery-powered systems. The PL2211 PSRR is 75dB at 100Hz and 70dB at 10kHz (see the Power-Supply Rejection Ratio vs. Frequency graph in the Typical Characteristic).

When operating from sources other than batteries, improved supply-noise rejection and transient response can be achieved by increasing the values of the input and output bypass capacitors, and through passive filtering techniques. The Typical Characteristics show the PL2211 line and load transient responses.

## Dropout Voltage

A regulator's minimum dropout voltage determines the lowest usable supply voltage. In battery-powered systems, this determines the useful end-of-life battery voltage. Because the PL2211 use a P-channel MOSFET pass transistor, their dropout voltage is a function of drain-to-source on resistance ( $R_{DS(on)}$ ) multiplied by the load current (see the Typical Characteristics).

**PACKAGE INFORMATION**

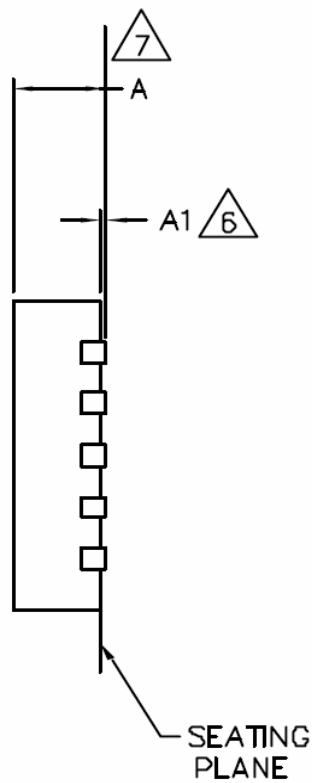
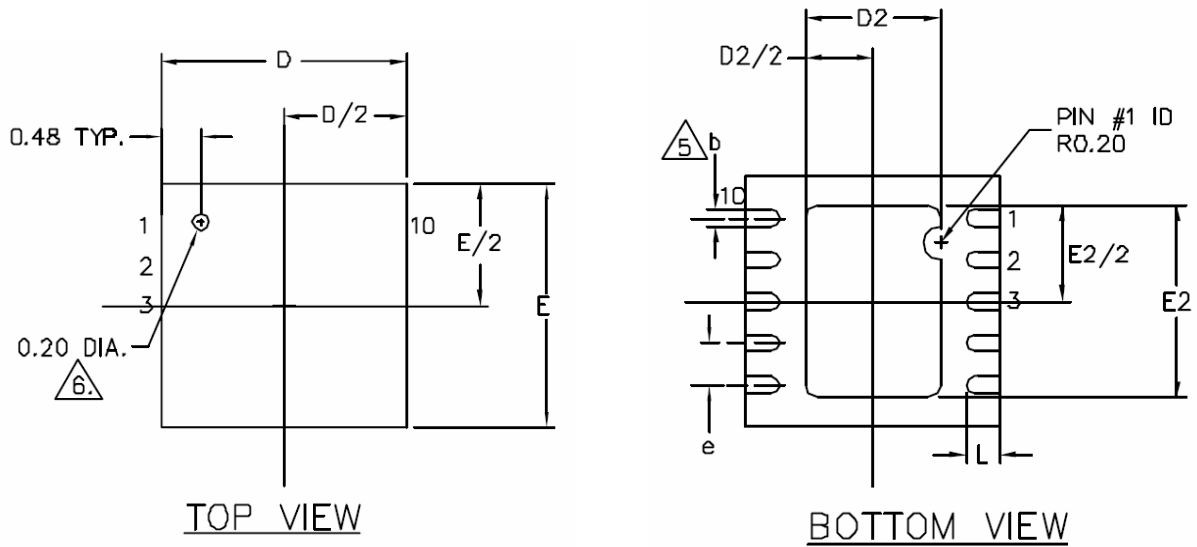

**10-pin 3mm x 3mm MLF Outline Dimension**



**DIMENSION:**

	DIMENSION (mm)		
	MIN.	NOM.	MAX.
A	0.80	0.85	1.00
A1	0.00	0.01	0.05
D	3.00 BSC		
D2	1.45	1.60	1.75
E	3.00 BSC		
E2	2.15	2.30	2.45
e	0.50 BSC		
L	0.35	0.40	0.55
b	0.18	0.23	0.30

**NOTE:**

1. ALL DIMENSIONS ARE IN MILLIMETERS.
  2. MAX. PACKAGE WARPAGE IS 0.05 mm.
  3. MAXIMUM ALLOWABLE BURRS IS 0.076 mm IN ALL DIRECTIONS.
  4. PIN #1 ID ON TOP WILL BE LASER/INK MARKED.
-  DIMENSION b APPLIES TO METALIZED TERMINAL AND IS MEASURED BETWEEN 0.20 AND 0.25 mm FROM TERMINAL TIP.
-  APPLIED ONLY FOR TERMINALS,
-  APPLIED FOR EXPOSED PAD AND TERMINALS.

## DISCLAIMERS

### **LIFE SUPPORT**

Power IC's products are not designed to be used as components in devices intended to support or sustain human life. Use of Power IC's products in components intended for surgical implant into the body, or other applications in which failure of Power IC's products could create a situation where personal death or injury may occur, is not authorized without the express written approval of Power IC's Chief Executive Officer. Power IC will not be held liable for any damages or claims resulting from the use of its products in medical applications.

### **MILITARY**

Power IC's products are not designed for use in military applications. Use of Power IC's products in military applications is not authorized without the express written approval of Power IC's Chief Executive Officer. Power IC will not be held liable for any damages or claims resulting from the use of its products in military applications.

### **RIGHT TO MAKE CHANGES**

Power IC reserves the right to change this document and/or this product without notice. Customers are advised to consult their Power IC sales representative before ordering.