

INTRODUCTION

Choosing a power supply or linear regulator for an application involves more than looking for the part with the lowest dropout voltage or lowest cost. It is quite difficult for an inexperienced person to select the right regulator IC for his specific application. Although the IC manufacturers promote the regulators with guarantee that their IC has a very low dropout voltages, these are often the most expensive part and not necessarily the best solution. A designer can choose the best regulator by considering the system/application specifications such as minimum and maximum input voltage, noise, load current and also the system cost. This article describes the process of choosing these ICs at its most fundamental level. First, it explains about the PL0300 regulator IC and then why power-supply ICs are necessary. Next, it shows how to choose from among the three most common power-supply ICs powered with DC voltages: linear regulators, switching regulators, and charge pumps. And along the way it provides tutorials that discuss more advanced power-supply topics, allowing you to expand your knowledge in the areas of specific interest or in the direction demanded by a particular project.

TYPICAL APPLICATION CIRCUIT

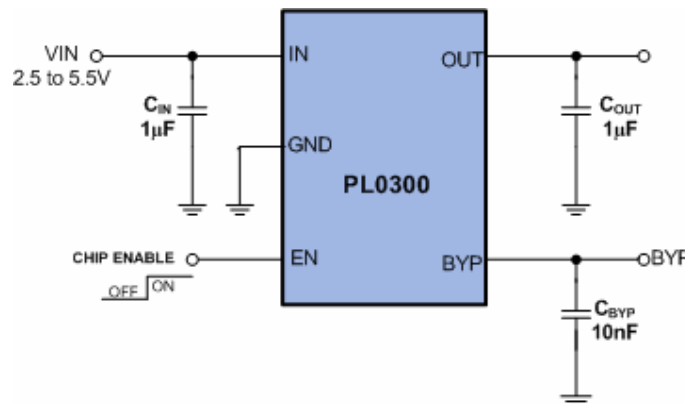

DETAILED DESCRIPTION

The PL0300 is an ultra-low-noise, low-dropout, low-quiescent current linear regulator designed for space-restricted applications. This device can supply loads up to 300mA. The PL0300 consists of a highly accurate band gap core, noise bypass circuit, error amplifier, P-channel pass transistor and an internal feedback voltage divider. The 1.0V band gap reference is connected to the error amplifier's inverting input. The error amplifier compares this reference with the feedback voltage and amplifies the difference. If the feedback voltage is lower than the reference voltage, the pass transistor gate is pulled low. This allows more current to pass to the output and increases the output voltage. If the feedback voltage is too high, the pass transistor gate is pulled high, allowing less current to pass to the output. The output voltage is feedback through an internal resistor voltage divider connected to the OUT pin. An external bypass capacitor connected to BYP reduces noise at the output. Additional blocks include a current limiter, over temperature protection, and shutdown logic.

The PL0300 features a 1Ω (typ) P-channel MOSFET pass transistor. This provides several advantages over similar designs using a PNP pass transistor, including longer battery life. The P-channel MOSFET requires no base drive, which considerably reduces quiescent current. PNP-based regulators waste considerable current in dropout when the pass transistor saturates. They also use high base-drive current under heavy loads. The PL0300 does not suffer from these problems and consume only 90µA of quiescent current in light load and 220µA in dropout condition.

The PL0300 features an active-high Enable input (EN) pin that allows on/off control of the regulator. The PL0300 bias current reduces to less than microampere of leakage current when it is shutdown. The Enable input is TTL/CMOS compatible threshold for simple logic interfacing. When EN is 'H,' the output voltage startup

rising time is 35 μ s typically at 300mA output current. Connect EN pin to IN pin for normal operation.

The PL0300 has a quick charge block to get the reference up very quickly by charging the BYP capacitor with very high current when the chip comes out of shut down. This quick charge block stops charging the BYP capacitor when the reference reaches 95% of its nominal value and then the chip switches out of quick charging mode to normal operating mode.

DC-DC Converter Tutorial

Why Power-Supply ICs?

The chief purpose of most power-supply ICs is to *regulate*. These devices take an unregulated input voltage and provide a regulated output voltage, that is, an output voltage that remains steady despite varying input voltage or output current. Sometimes regulators create a regulated output voltage from a regulated input voltage. In that case, the regulator's function is to change the input voltage to another voltage level, without necessarily improving the voltage regulation.

You can give power to portable equipment directly by a battery, but sometimes it creates problems. The circuit of that equipment most likely operates within a narrow voltage range. In that case if the battery voltage exceeds that range the equipment might be harmed. But adding a regulator ensures that the circuit receives the appropriate voltage and the equipment also remains safe.

The battery's internal resistance might also create a problem if there is no regulator. Because the circuitry within the portable equipment often demands a varying level of supply current not constant current. This varying current, drawn from the battery, creates a varying battery voltage due to the battery's internal resistance. Portions of the circuitry might object to these battery-voltage variations (in other words, the *power-supply rejection ratio* of the circuitry's various components might not be sufficient to reject these voltage variations). To combat this problem, a regulator maintains a steady output voltage despite these varying load currents. A regulator provides this steady voltage, because its active circuitry maintains an output resistance that is significantly lower than the battery's series resistance.

This attempt to do without a regulator emphasizes the necessity of the steady voltage that regulators provide, despite varying input voltage or output current. In most cases, switching and linear regulators, along with regulated and unregulated charge pumps, serve an additional purpose: They create a voltage of a different magnitude from the voltage that powers them. This accounts for the name *DC-to-DC converter*. Technically speaking, all three types of power-supply ICs discussed here are DC-to-DC converters; however, this name is normally reserved for switching regulators.

Somewhat limited when converting voltage levels, a linear regulator can only produce a voltage lower than the voltage supplying it. Being much more versatile, a switching regulator can step up (boost), step down (buck), or invert (change the polarity of) its supply voltage. Charge pumps perform these same three operations, but with limited output-current capability.

Exceptions to the idea that power-supply ICs create voltages of a different magnitude than the voltages fed to them are most often found in transformer-coupled converters. It's not unusual to see a transformer-coupled converter whose output voltage equals its input voltage. See **Figure 1**. In most cases, the sole purpose of a converter configured this way is to provide isolation, which prevents a DC connection between the input voltage supplied to the converter and the output voltage created by the converter. Isolation is often used for safety reasons. The power for circuitry connected to a patient through electrodes, for example, is isolated from the power derived from a wall socket to protect against the risk of shock. But you don't need to be in a hospital to require isolation. Nearly all consumer electronic products isolate the AC line from the operating circuitry, especially

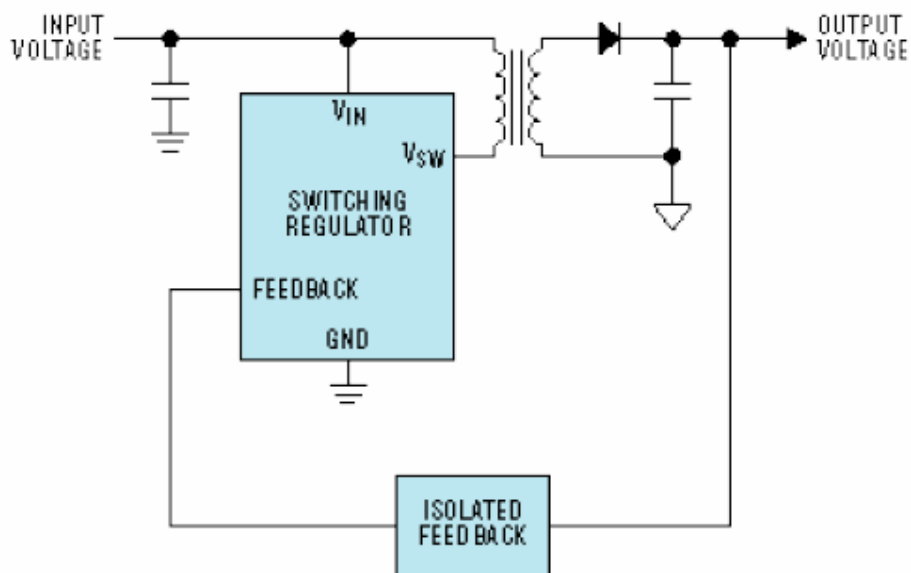

Figure 1. This transformer-coupled switching-regulator circuit isolates the input voltage from the output voltage. Power-supply designers often use an optocoupler to isolate the circuit's output from the regulator's feedback pin.

The advantages and disadvantages of linear regulators, switching regulators, and charge pumps will now be explained. The material that follows will enable you to choose from among these power-supply ICs.

Linear Regulators

Linear regulators are often the smallest, usually the least expensive, and always the least noisy of the various types of power-supply ICs. See **Figure 2**. Use a linear regulator if it's appropriate for your application, especially because a linear-regulator circuit is more likely to work correctly the first time than circuits built around other types of power-supply ICs.

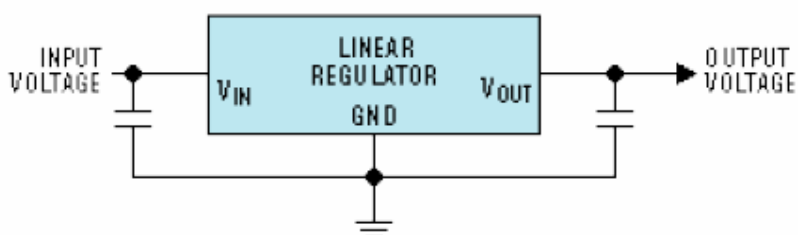

Figure 2. A linear regulator both steps down and regulates the voltage supplied to it with a minimal number of external components. Because these devices contain no switching elements, they generate little noise. Also, the circuit-board layout of linear regulators is less critical than for switching regulators and charge pumps.

Why would you use any power-supply IC other than a linear regulator? One reason: A linear regulator can only provide an output voltage that's smaller than its input voltage. As mentioned above, if you wanted to create a voltage that's higher than the input voltage or of opposite polarity, you'd have no choice but to use a switching regulator or a charge pump.

Another reason: Efficiency. Converting a voltage to another voltage always wastes power. In the ideal case where a regulator wastes no power, its efficiency rating would be 100%. If half the power supplied to a regulator found its way to the regulator's load, its efficiency would be 50%.

A linear regulator is usually, though not always, less efficient than a switching regulator. You can calculate a

linear regulator's efficiency by dividing its output voltage by its input voltage. (This formula is sufficiently accurate if the current that powers the regulator—the regulator's supply or quiescent current—is a small percentage of the current drawn from the regulator's output, and in most cases it is.) Thus, when the voltage of the source powering a linear regulator is near the regulator's output voltage, efficiency is high; in that case, a linear regulator may be a better choice than a switching regulator.

A high-efficiency regulator provides a distinct advantage in portable equipment, as less wasted power results in longer battery life. You may need a high-efficiency regulator for another reason: Wasted power is dissipated as heat. Thus, a high-efficiency power supply often suits wall-powered equipment as well as portable equipment. It can reduce the temperature within an enclosure to a tolerable level in either case.

Switching Regulators

Switching regulators share none of the advantages of linear regulators. Switching regulators consume more board area (except perhaps when a linear regulator requires a heatsink to dissipate the power lost within it), cost more, and generate more noise than their linear counterparts. Yet for years switching regulators have been enormously popular with power-supply designers. Why? The reason is because these devices boast excellent efficiency when subjected to many combinations of input voltage and load current (as high as 96% for both stepup and step-down switchers, although a step-down is typically more efficient, and up to 90% for an inverter). Also, if you need to step up, step down, or invert a voltage, you'll find that switching regulators are the only devices capable of these operations for load currents above approximately 125mA. You can use charge pumps to perform these operations, but the load currents these devices allow are limited. It's simply too expensive to make the switches internal to charge pumps large enough to handle load currents above the 125mA level just mentioned, although a few charge pumps supply several hundred milliamps.

Switching regulators are so named because they switch a power transistor, which, when used in conjunction with an inductor, efficiently converts one voltage to another. See Figure 3. When these power transistors switch, they do so very quickly, as these fast transitions improve the regulator's efficiency. To understand why, first consider the power transistor's power dissipation when it isn't transitioning. When the transistor is off, voltage appears across it, but no current flows through it; thus, no power is lost. When the transistor is on, a small voltage appears across it, while appreciable current may flow through it; thus, typically, a small amount of power is lost. When the power transistor transitions from an off state to an on state, or vice versa, voltage appears across the transistor, while current flows through it; therefore, appreciable power may be lost. Speeding up the switching process reduces these *transition losses*.

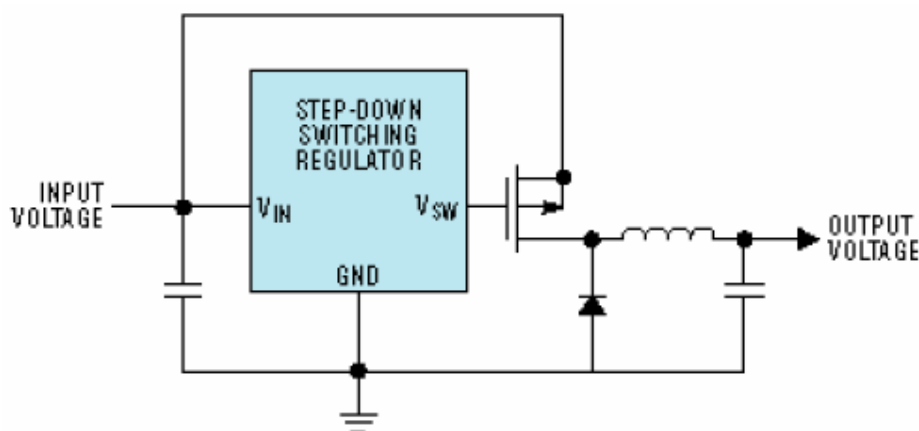

Fig

These fast transitions, along with the heavy currents that often flow in these circuits, make circuit-board layout critical. Because switching-regulator circuits require a well-thought-out layout and because the components external to the switching-regulator IC must be specified correctly, of the various types of power supplies switching regulators require the most careful design.

Charge Pumps

Charge pumps constitute the least-known category of the three types of power-supply ICs discussed here. These devices perform the same functions as switching regulators, but without an inductor. Instead, charge pumps use capacitors to step down, invert, or boost the voltages that power them. See **Figure 4**.

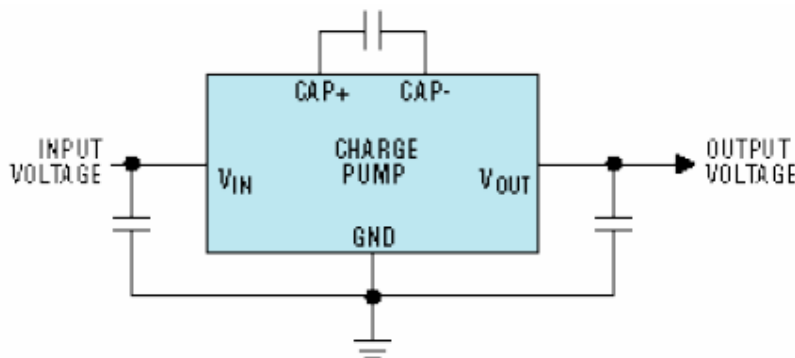

Figure 4. Like switching regulators, charge pumps step down, step up, and invert voltages, but use capacitors instead of an inductor to perform these operations. In most cases, charge pumps handle lower output currents than switching regulators. Although the topologies vary somewhat, the circuit shown here is representative of both regulated and unregulated charge pumps, regardless of whether they step up, step down, or invert.

Charge pumps come with both unregulated and regulated outputs. With an unregulated charge pump, as a circuit connected to its output draws more and more current, its output voltage drops proportionately. The charge pump's output impedance is thus essentially a fixed resistance. Unregulated charge pumps, when used in the inverting mode, provide an output voltage equal to the voltage powering the device, but with opposite polarity. As load current increases, the magnitude of this voltage drops, as discussed above. When used in the doubling mode, these charge pumps precisely double the applied voltage, and the output voltage also drops as load current increases.

Regulated charge pumps can step up, step down, or invert the applied voltage. Unlike unregulated charge pumps, these devices provide output-voltage levels that aren't strictly dependent on the voltage level fed to them. Thus, these devices could, for example, create a 5V output from a 3.3V input. Also, because they're regulated, as the output current increases, the output voltage remains essentially constant. As mentioned above, the amount of current that can be drawn from these devices, as well as from unregulated charge pumps, is limited; the upper end is about 125mA, although there are a few parts that handle several hundred milliamps. It's not economical to build charge pumps that supply large load currents. Instead, inductor-based switching regulators are well suited for this situation.

A charge pump switches the capacitors connected to it, and thus creates noise. For several reasons, this noise is usually of smaller magnitude than a switching regulator's noise. For one, load currents are lighter. Also, because these circuits don't include an inductor, no magnetic noise is created. Finally, when a charge pump interrupts the current flowing through a capacitor connected to it, a voltage spike isn't created. A switching regulator interrupting the current flowing through an inductor usually creates a voltage spike.

Capacitor selection

To achieve a low output ripple, all capacitors should be ceramic capacitors because of their low equivalent series resistance (ESR). The low ESR of the capacitors ensures minimum time constant when charging and discharging. The low ESR of C_{IN} and C_{OUT} is required to reduce the spikes that occur during the turnover from the transfer phase of one charge pump to that of the other. The lower the ESR of C_{OUT} , the lower is the output voltage spike. A 1- μ F ceramic input and output capacitor is sufficient for most applications. Increasing this value provides better input-voltage filtering.

This capacitors must be located a distance of not more than 1cm from the input and output pin and returned to a clean analogue ground.

Conclusion

Linear regulators provide significant advantages over switching regulators in simplicity, cost, and output noise, but not efficiency. When applied to battery-operated portable equipment, battery life is more important than individual circuit efficiency, therefore the choice between an LDO and a switching regulator is not so obvious. In addition, the particular battery characteristics, whether alkaline, NiCd, NiMH, or Lithium (Li+), must be considered. But if there is any issue of cost then it is the best to us a linear regulator.