

300mA High accuracy Low noise LDO Regulator

FEATURES

- Guaranteed 300mA output
- High output initial voltage accuracy: $\pm 1\%$
- Ultra low output noise: $115\mu V_{RMS}$
- Low ground current: $120\mu A$
- Very low dropout: $175mV @ 300mA$
- Zero shutdown supply current
- TTL-logic-controlled enable input
- Thermal and current limit protections
- Low ESR capacitor compatibility
- Ultra low drop load transient response
- Ultra fast line transient response
- Low profile 5-lead SOT25, SC-70-5 and WDFN-6L 2x2 packages
- Fixed options 1.5V, 1.8V, 2.5V, 2.8V, 3.0V and 3.3V

APPLICATIONS

- Cellular and cordless phones
- Wireless LAN cards
- Palmtop computers
- Personal communication equipment
- Pen drives
- Bluetooth devices

DESCRIPTION

The PIC6193 is a CMOS low dropout linear regulator with ultra-low-noise output, very low dropout voltage and very low ground current.

The PIC6193 operates from a 2.5V to 5.5V input voltage range and delivers up to 300mA, with low dropout of 175mV. The other features of PIC6193 include short-circuit protection and thermal-shutdown protection.

The PIC6193 is designed especially for battery-powered portable devices. Its low noise feature makes it ideal for noise-sensitive personal communication applications. Other key application areas for PIC6193 also include palmtop computers, PCMCIA cards and WLAN cards.

The PIC6193 is available in small 5-lead SOT25, SC-70-5 and WDFN-6L 2x2 packages with fixed output voltage versions.

TYPICAL APPLICATION CIRCUIT

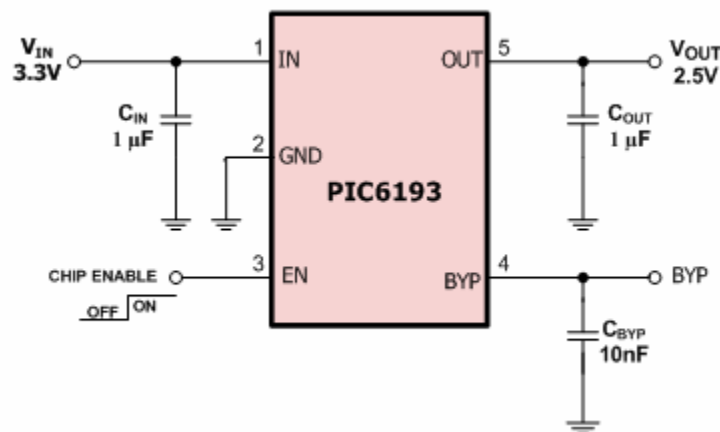

ELECTRICAL CHARACTERISTICS

($V_{B_{INB}}=V_{B_{OUT(NOMINAL)B}}+1V$ OR $2.5V$ (whichever is greater), $V_{B_{ENB}}=V_{B_{IN}}$, $C_{B_{INB}}=C_{B_{OUTB}}=1\mu F$, $I_{B_{OB}}=1mA$, $T_{B_{AB}}=25^{\circ}C$, unless otherwise specified)

Symbol	Parameter	Test Conditions	Min.	Typ.	Max.	Unit
V_{IN}	Supply voltage		2.5		5.5	V
ΔV_{OUT}	Output voltage accuracy	$I_{OUT} = 1mA$	-1.0		1.0	%
ΔV_{LOAD}	Load regulation	$I_O = 1mA$ to $300mA$			0.65	%
ΔV_{LINE}	Line regulation	$V_{IN} = V_{OUT(NOMINAL)} + 1V$ to $5.5V$, $I_{OUT} = 1mA$			0.075	%/V
V_{DP}	Dropout voltage (Note 1)	$I_{LOAD} = 300mA$, $V_{OUT} > 2.8V$		175	210	mV
		$I_{LOAD} = 200mA$, $V_{OUT} > 2.8V$		115	140	mV
$I_{B_{OB}}$	Maximum output current	Continuous	300			mA_{RMS}
I_{LIM}	Current limit	$R_{LOAD} = 1\Omega$	400	600		mA
$I_{B_{OB}}$	Standby current	$V_{EN} = GND$, Shutdown		0.01	0.5	μA
$I_{B_{GB}}$	Ground pin current	$I_{LOAD} = 1mA$	95	120		μA
PSRR	Ripple rejection, $C_{OUT} = 1\mu F$ $I_{OUT} = 50mA$,	$f = 100Hz$			62	dB
		$f = 10KHz$			60	dB
e_{NO}	Output voltage noise	$C_{OUT} = 1\mu F$, $I_{OUT} = 200mA$ $F = 10Hz$ to $100kHz$		115		μV_{RMS}
	Thermal shutdown temperature			160		$^{\circ}C$
	Thermal shutdown hysteresis			20		$^{\circ}C$
V_{IH}	Logic input high voltage (EN)	$V_{IN} = 3V$ to $5.5V$, Start-Up	1.2			V
V_{IL}	Logic input low voltage (EN)	$V_{IN} = 3V$ to $5.5V$, Shutdown			0.4	V
I_{EN}	EN input bias current	$V_{EN} = GND$ or V_{IN}		0	100	nA
	Shutdown exit delay	$V_{EN} = 0$ to $5.5V$, $C_{BYP} = 10nF$ $C_{OUT} = 1\mu F$		55		μs
	Shutdown discharge resistance			400		Ω

Note-1: The dropout voltage is defined as $V_{IN} - V_{OUT}$, which is measured when V_{OUT} is $V_{OUT(NOMINAL)} - 100mV$.